



Westland Horticulture Limited,  
14 Granville Industrial Estate,  
Granville Road, Dungannon, Co Tyrone, BT70 1NJ  
Tel: +44 (0) 1480 443789  
[www.gardenhealth.com](http://www.gardenhealth.com)

[customerservice@westland.com](mailto:customerservice@westland.com)

91xxxxx

105 mm

148,5 mm

**EN - GUARANTEE** / The product is covered by a 30 year guarantee at the following conditions: • the guarantee starts from the date of purchase, and only covers product defects (material or manufacturing defects). • The activation of the guarantee is subjected to the presentation of proof of purchase (tax receipt), together with the allegedly defective product. • In case of justified claim, the product will be replaced or repaired. • All defects must be notified to the store from where the product was purchased within 10 days from their discovery. If no satisfactory response is received from the store, please contact [customerservice@westland.com](mailto:customerservice@westland.com). • The replacement or repair of the defective product will not entail the start of a new warranty period for the product.

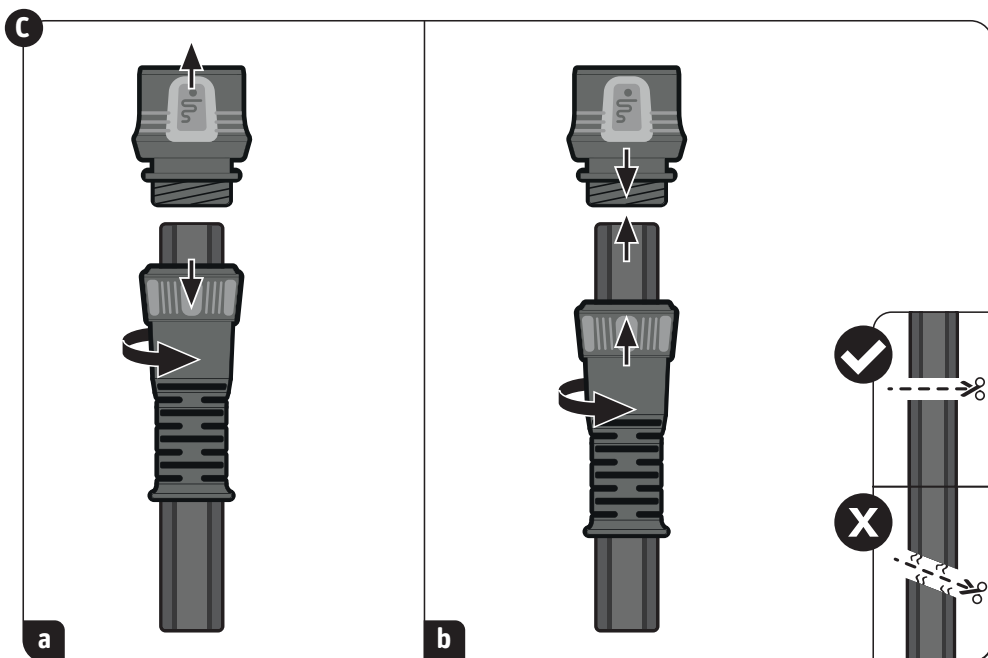
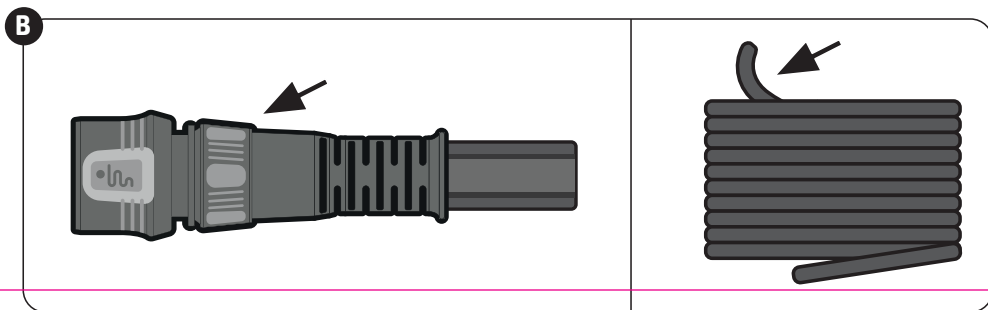
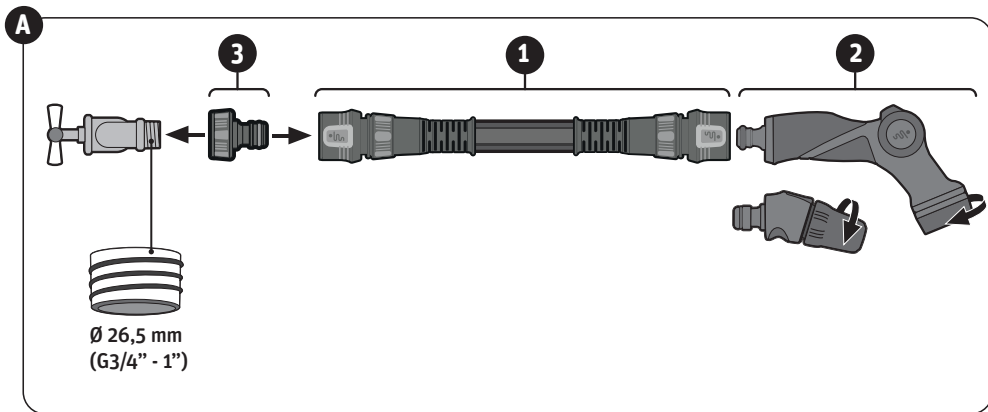

## USE AND MAINTENANCE MANUAL

Please read these instructions very carefully before using the product. Improper use can lead to injury.

Thank you for purchasing Smartflo, a revolutionary product that will change the way you do things! For more information visit: [www.gardenhealth.com](http://www.gardenhealth.com)

### Pack content\* (A)

- no. 1 hose with automatic couplings (1)
- no. 1 multifunction watering gun (2)
- no. 1 tap connector, Ø 34mm and 26.5 mm (G 1" - 3/4") (3)

### Technical details

- Internal Ø 12,5mm / 15 mm approximately
- Optimum operating pressure: 3 - 7 bar
- Hose bursting pressure (at 20 °C): 20 bar
- Temperature of use: -40 °C +80 °C
- UV ray resistant

### First use (B)

Remove Smartflo from its packaging and unwind it completely starting from the end at the centre of the reel, as shown in the image, before connecting it to the tap.

### Warnings

Safety warnings:

- Smartflo is only intended for outdoor watering applications.
- Not suitable for use with hot water.
- Do not leave under pressure when not in use.
- Make sure that children cannot access Smartflo unsupervised.
- To avoid leaks at the coupling joints, regularly check that the couplings are tightly screwed to the hose.
- Hose damage can be repaired as shown in the images. (C)

\*1. "packaging is a registered community design";

\*2. The hose is a patented product.